



CITEL



COAXIAL RF SURGE PROTECTORS

RF SURGE PROTECTION OR RF COAXIAL SPD

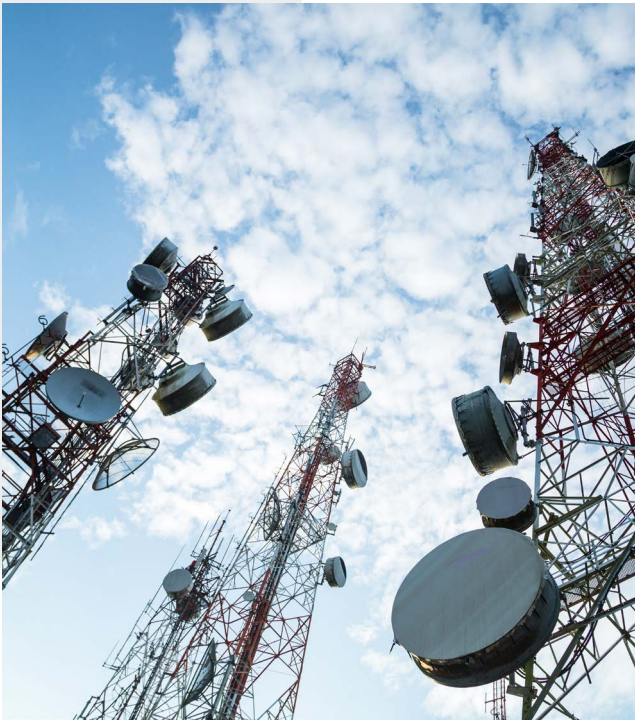

PROTECTION OF RADIO COMMUNICATION EQUIPMENT

Radio communication equipment deployed in fixed, nomadic or mobile applications are especially vulnerable to lightning strikes because of their application in exposed areas. The most common disruption to service continuity results from transient surges originating from direct lightning strikes to the antenna pole, surrounding ground system or induced onto connections between these two areas.

Radio equipment utilized in CDMA, GSM/UMTS, WiMAX or TETRA base stations, must consider this risk in order to insure uninterrupted service. CITEL offers three specific surge protection technologies for Radio Frequency (RF) communication lines that are individually suited for the different operational requirements of each system (Filter, GDT and quarter wave).

RF SURGE PROTECTION TECHNOLOGY

P8AX series (Gas Tube Protection)

The gas discharge tube (GDT) is the only surge protection component usable on very high frequency transmission (several GHz) due to its very low capacitance. In a coaxial surge protector, the GDT is connected in parallel between the central conductor and the external shield. When its sparkover voltage is reached, during an overvoltage event, the line is briefly shorted (arc voltage). The sparkover voltage depends on the rise front of the overvoltage. The higher the dV/dt of the overvoltage, the higher the sparkover voltage of the surge protector is.

When the overvoltage disappears, the gas discharge tube returns to its original condition of high isolation and is ready to operate again. The gas tube is removable, making maintenance rapid in the end-of-life scenario (short-circuit).

The greatest advantage of this technology is its very wide bandwidth: from DC (so, compatible with DC voltage injection) to several GHz.

Main characteristics:

- » Insertion losses < 0,2 dB
- » VSWR < 1,2
- » I_{max} : 20 kA (8/20 μ s)
- » Frequency range from DC to 7 GHz
- » Connectors : 7/16, 4.3-10, N, TNC, BNC, SMA, F, UHF
- » Waterproof IP65

Main characteristics VG option:

- » I_{max} : 6 kA (8/20 μ s)
- » Connector : 4.3-10, N, F
- » Prevents the short-circuit of the transmitter (output) and the receiver (input) during a disturbance

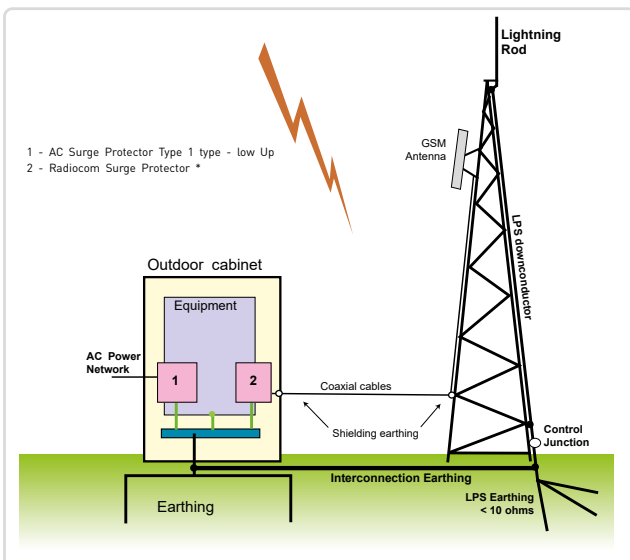
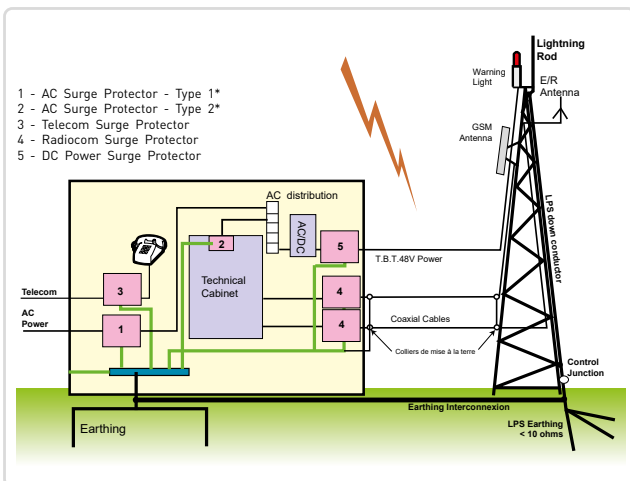

* Type referring to IEC standards

CNP/CXP series (GDT protection) and CXP-DCB series (DC Blocked Protection)

CXP protectors are based on GDT to provide high discharge current capability without destruction. These type of products allows for installation in ungrounded systems. In these cases, the CXP isolates the shield from the earth ground and is typically found in applications including wireless radio terminals and TV monitors (antenna, cable or satellite).

CXP-DBC version is a relevant hybrid association between a filter stage and a gas tube : this configuration has the advantage of reducing low frequency disturbances (DC and lightning voltages) while providing a high discharge current capability.

Main characteristics (CXP):

- » isolated ground through GDT
- » Insertion losses < 0.5 dB
- » VSWR < 1.3
- » I_{max} : 20 kA (8/20μs)
- » Frequency range from DC to 1000 MHz
- » Connectors : N, BNC, SE, F...

Main characteristics (CXP-DBC):

- » "DC Block" feature
- » Insertion losses < 1 dB
- » VSWR < 1.2
- » I_{max} : 20 kA (8/20μs)
- » Frequency range from 125 MHz to 1000 MHz
- » Connectors : N

PRC series (Quarter Wave Protection)

Quarter Wave DC Blocked Protection is an active band pass filter. It has no active components. Rather the body and corresponding stub are tuned to one quarter of the desired wave length. This allows only specific frequency bands to pass through the unit. Since lightning operates only on a very small spectrum, from a few hundred kHz to a few MHz, it and all other frequency's are short-circuited to ground. The filter may be selective (narrow band or wide-band), according to the calculation of various mechanical elements.

The PRC technology can be selected with very narrow band or wide band depending on the application. Surge current withstand is the depending on connector type. Typically, a 7/16 Din connector can handle 100kA 8/20μs while an N-type connector can handle up to 50kA 8/20μs.

AC/DC power injection is not possible with this technology typical application is the protection of radio lines that do not have a source voltage

Main characteristics :

- » Insertion losses < 0.2 dB
- » VSWR < 1.2
- » Broadband and narrowband units available
- » Frequency range:
 - 690-2700 MHz
 - 800-2200 MHz
 - 400-500 MHz
 - 870-950 MHz
 - 1700-1950 MHz
 - 1800-2400 MHz
 - 4800-6000 MHz
- » Best PIM performance: less than 160 dBc with 4.3-10 connector
- » I_{max} : up to 100 kA (8/20μs)
- » Connectors : 7/16, N, BNC, TNC, 7/8 cable

RF SURGE PROTECTORS DIAGRAMS

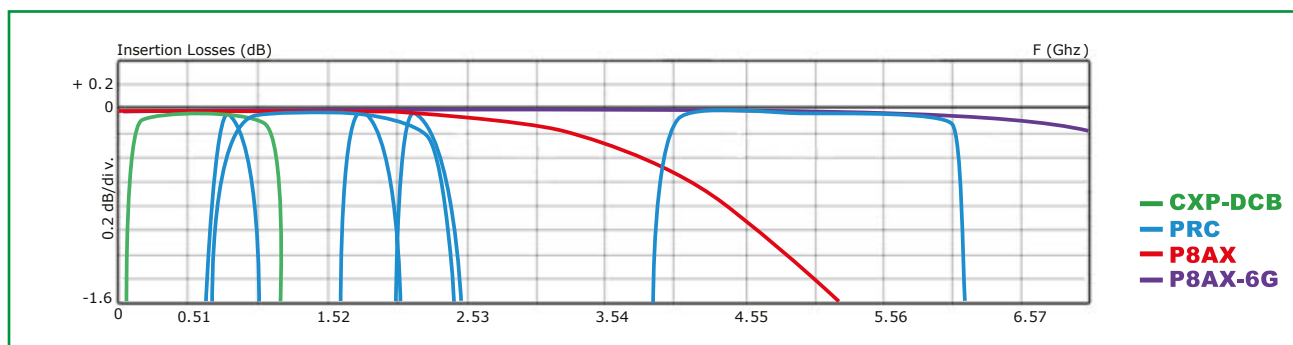
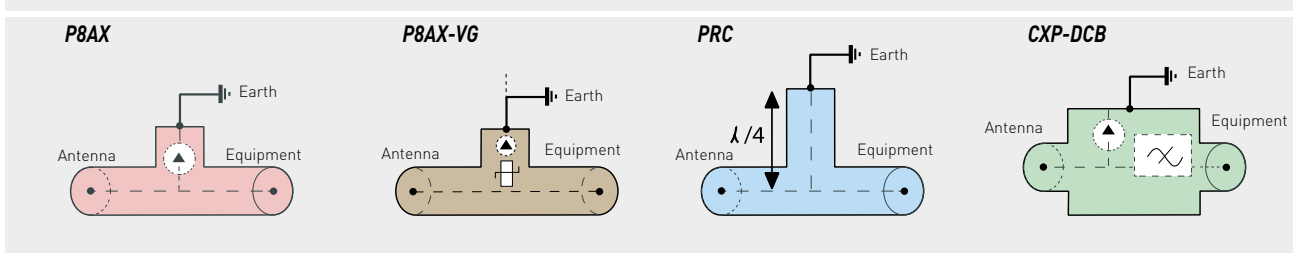

RF SURGE PROTECTION or RF COAXIAL SPD

COAXIAL SPD SPECIFIC PARAMETERS

RF transmission parameters

Coaxial protectors are intended to pass through a desired RF signal with minimum loss or disturbance. When RF energy enters a protector, the energy is, in some combination, passed through, reflected back, and dissipated within the device. The fundamental RF performance parameters of a coaxial protector are:

- Operation frequency range
- Insertion Loss : the loss in load power due to the insertion of the coaxial protector, measured in decibels (dB)
- Return Loss : part of signal which is lost due to reflection of power at a line discontinuity or mismatched coaxial protector, in decibels (dB)
- VSWR : Voltage standing Wave Ratio – ratio of U_{max}/U_{min} on a RF transmission line
- PIM (Passive Intermodulation) : non-linear characteristics of coaxial protectors cause undesirable signals by modulation effects in the case of several carriers being transmitted.

Connectors Surge current parameters

- General parameter from standard (I_n , I_{max} , I_{imp} refer to standards)
- Let-Through Energy :
Energy through the surge protector when a standardized impulse is applied to the input. In most cases the input is a combination wave 4kV 1.2/50 μ s – 2kA 8/20 μ s. The output of the protector is burdened by 50 Ω , and the resulting waveform is measured. The let-through energy, in Joules, is calculated from the peak voltage/current and integrated pulse width across the load.

F_Female



F_Male



716_Female



716_Male



BNC_Female



BNC_Male



N_male_female



SMA



TNC_Female



TNC_Male



4.3-10_Female



4.3-10_Male



SPD TECHNOLOGIES COMPARISON

Table below allows comparison between the 3 technologies of RF coaxial surge protectors, in order to select the right solution regarding the application and the requirements.

Technology	Gas Discharge Tube (GDT)	DC Block	Quarter wave (1/4)
CITEL series	P8AX	CXP-DCB	PRC
			
Principle	Switching	Switching + Filter	1/4 wave filter
Residual voltage (under standardized test condition: 1kV/μs surge voltage and/or surge current [8/20μs])	Depending on version, it can be from 600V to 2400V for typically 200 ns and then 10V during surge current flowing time.	Less than 600V for typically 200 ns and then 0V during surge current flowing time.	< 20 V during all surge duration.
Frequency range	DC up to 7 GHz (dependent on the coaxial connector and the impedance)	125-1000 MHz	Broadband and narrow band (GSM, DCS1800, PCS, DECT, GPS....) up to 5800 MHz
DC/AC power injection	Possible	Blocked	Not compatible
Typical 8/20μs surge current capability	20 kA	20 kA	Depending on the connector: 100kA for the 7/16, 50kA for the N
Typical 10/350μs lightning current capability	2.5 kA	2.5 kA	Function of the connector : 25kA to 50kA
Typical let through energy (on 50 Ohms load for 4kV/2kA combined surge)	300μJ	300μJ	5μJ
Maintenance	Possible to replace the GDT (but not recommended)	None	None
End of life detection	RF line shorted	RF shorted	No end of life excepted due to environmental stress
Connectors	N, BNC, TNC, UHF, SMA, 7/16, 4.3-10 option VG : 4.3-10, N, F	N	7/16, N, TNC, 4.3-10....

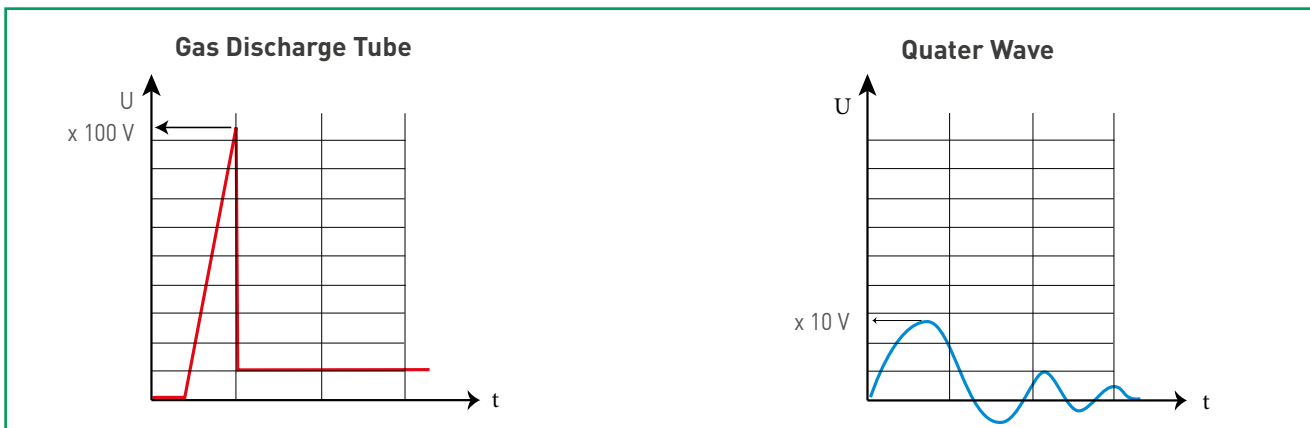

RF SURGE PROTECTION or RF COAXIAL SPD

TYPICAL RADIO FREQUENCY BANDS

LF : Low Frequency	30-300 kHz
MF : Medium Frequency	300-3000 kHz
HF : High Frequency	3-30 MHz
VHF : Very High Frequency	30-300 MHz
UHF : Ultra High Frequency	300-3000 MHz
SHF : Super High Frequency	3-30 GHz

A FEW MICROWAVE APPLICATIONS

Tetra, Tetrapol	380-512 MHz
GSM850	824-894 MHz
Tetra	870-925 MHz
GSM 900	880-960 MHz
GPS	1575 MHz
GSM 1800	1710-1785 MHz
GSM 1900	1850-1990 MHz
DECT	1880-1900 MHz
WCDMA/TD-SCDMA	1850-2025 MHz
UMTS (IMT-2000)	1885-2200 MHz
WLL (WiMax)	2400-5825 MHz

INSTALLATION, LOCATION OF THE SPD

The efficiency of coaxial protectors is highly dependent on proper installation, in particular their connection to the earthing network of the installation.

The following installations rules must be strictly observed to ensure the efficiency:

- » Equipotential bonding network: all the bonding conductors of the installation must be interconnected and connected to the installation earthing network.
- » Optimized connection of the protector to the bonding network: to reduce the residual voltages during lightning discharge currents, the connection of the protector to the bonding network must be as short as possible (less than 50 cm) and has a proper cross section (at least 4 mm²).
The «feedthrough mounting» versions perfectly meet all these requirements.
Warning: Carefully remove all paintings or insulating coatings to ensure good contact..
- » Location of the protectors: they should preferably be placed at the entrance of the installation (to limit the penetration of lightning currents) and also near sensitive equipment (to enhance protection).

MOUNTING

The proper mounting of a coaxial surge protector is largely dependent on its connection to a low impedance grounding system. The following rules must be strictly observed:

Equipotential Grounding System: All the bonding conductors of the installation must be interconnected to each other and connected back to the grounding system.

Low Impedance Connection: The coaxial surge protector needs to have a low resistance connection to the Ground System.

Note: Depending on models, CITELE Coaxial SPD's family is suitable to be mounted outdoor and can be immersed as soon as the connection to the cable is realized to be immerse as well.

Feedthrough mounting

Direct mounting of the surge protector on the grounded frame at the installation entrance (or on specific bracket see p. 177) :

- » Perfect connection to the bonding network
- » Best location (conduction of the surge currents at the entrance of the installation)
- » Good mechanical withstand.

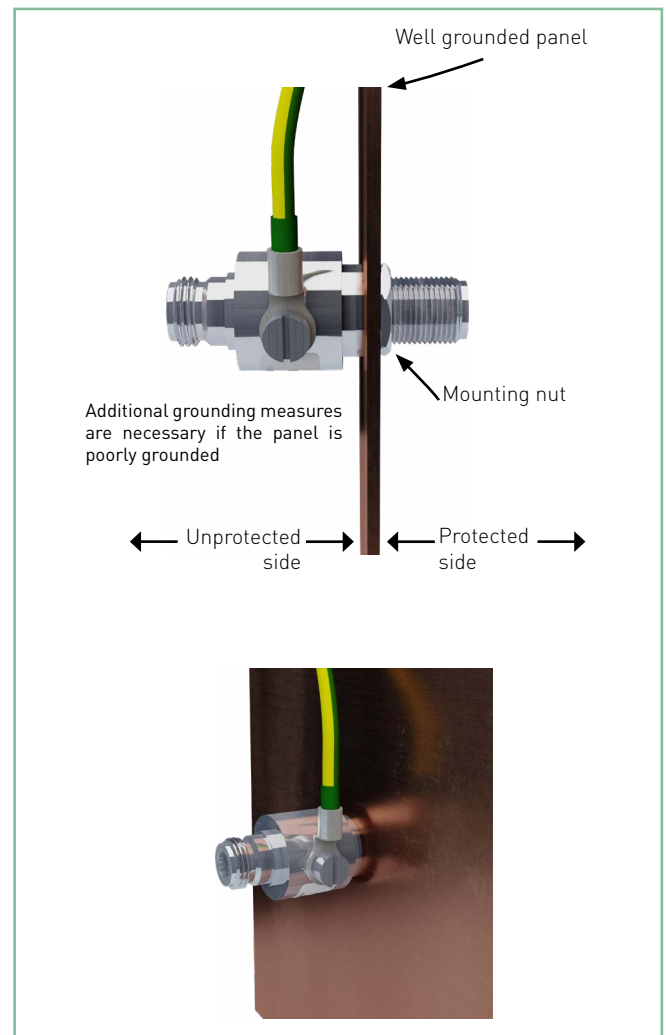

Note: Unprotected side and Protected side concept is a recommendation to keep the box concept principle but surge protection is bidirectional

Alternative mounting

Connection to the bonding network by wire (4 mm² minimum and shortest length possible).

STANDARDS

Various standards address Coaxial surge protection . CITELE SPD are designed to be compliant with the following:

IEC 61643-21 : Low voltage surge protective devices – Part 21: Surge protective devices connected to telecommunications and signaling networks – Performance requirements and testing methods

EN 61643-21: Low voltage surge protective devices – Part 21: Surge protective devices connected to telecommunications and signaling networks – Performance requirements and testing methods

UL497C : Protectors for Coaxial Communications Circuits

UL497E : Outline Of Investigation For Protectors For Antenna Lead-In Conductors

SPD SELECTION

Peak power and connectors

Peak power is the maximum transmitted power that the SPD can handle without damage or unwanted action.

The connector is mainly set by the installation. The characteristic Impedance of the SPD is often linked to a specific type of connector but it may happen that a connector type exists with 2 different impedances (50 ohms and 75 ohms are possible with BNC connector).

For PRC range, the admissible peak power is depending on the connector. See declared values in dedicated datasheet.

For P8AX, CXC, CXP ranges, the admissible peak power is linked

- to the nominal spark over voltage: of the selected GDT,
- to the VSWR,
- to the possible injected ac/dc power,
- to the Impedance and
- to the connector type (not big impact for P8AX).

Following tables are showing how to select both PA8X spark over voltage of the GDT for 50 ohms with no injected ac/dc power and Connector selection. For CXP and CXC ranges, the selection principal is similar to P8AX range, and details are provided on various datasheets in the following pages.

CITEL model	Nominal sparkover voltage	Max. peak power with	
		VSWR<1.2	VSWR <1.5
P8AX09	90 V	25 W	24 W
P8AX15	150 V	70 W	67 W
P8AX25	250 V	190 W	188 W
P8AX50	500 V	780 W	762 W

CITEL model	Connectors
P8AX-716	7/16
P8AX-4310	4.3-10
P8AX -N	N
P8AX - T	TNC
P8AX -B	BNC
P8AX -SMA	SMA
P8AX -F	F
P8AX -U	UHF

When ac/dc power is injected, special care must be applied. As an example, if 48V dc power is superimposed with RF signal a P8AX25 is limited to 114W for VSWR ≤ 1,2. Consult our experts for further information.

REFERENCE SYSTEM

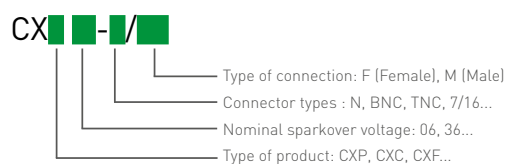
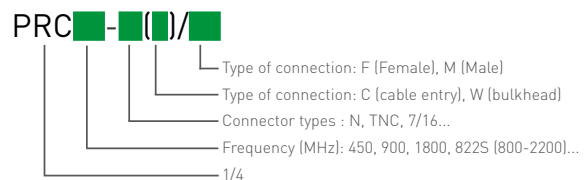
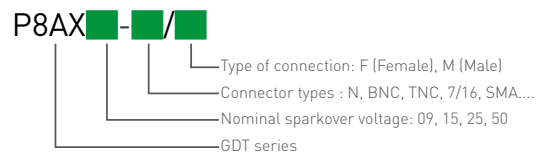

RF SURGE PROTECTION or RF COAXIAL SPD

EXAMPLE FOR SPECIFIC REQUIREMENT USING A PRC827-N/MF

Main features description of the Quarter-Wave Surge Protector used for the example



- » Maintenance Free Design
- » Low Insertion Loss
- » Several Wide to Narrow Band Applications
- » $I_{max} > 50kA$, Peak power = 1,5kW, $Z = 50\Omega$
- » IP66 Classification
- » DC Block (Short Circuit)

To select the proper RF protection, the main point is to know exactly what will be the frequency of use and the minimum transmission characteristic that the system is able to accept for proper communication. The full system must then be known as each single element of the system is willing to disturb or attenuate the RF signal. Connectors, cable and any other components or equipment that is comprised in this system must be considered. In general a VSWR lower than 1.2 is more than acceptable for a system to work properly this is why the wide band for single RF equipment is limited by the frequencies that are corresponding to this ratio. In some extreme case, the specific need is to get lower VSWR for the full system. It is mandatory to optimize each single equipment because each losses is simply cumulated along the transmission line (Coaxial cable equipped with various equipment such as SPDs). For this example, the hereunder plots made on our PRC827-N/MF, are showing transmission characteristics depending on frequencies that are better or even much better than general declared values.

In such specific needs, the Surge protection must be selected in regard to the working frequency band.

Note: in general all RF characteristics for a device are linked and vary in the same way depending on the frequency.

In our example, if the requested working frequency band is 2.7 GHz to 2.72 GHz, the selected SPD is presenting exceptional RF characteristics in this frequency range (VSWR<1,05) even if general features state that VSWR is between 1 and 1,2 from 0,8 GHz to 2,8GHz.

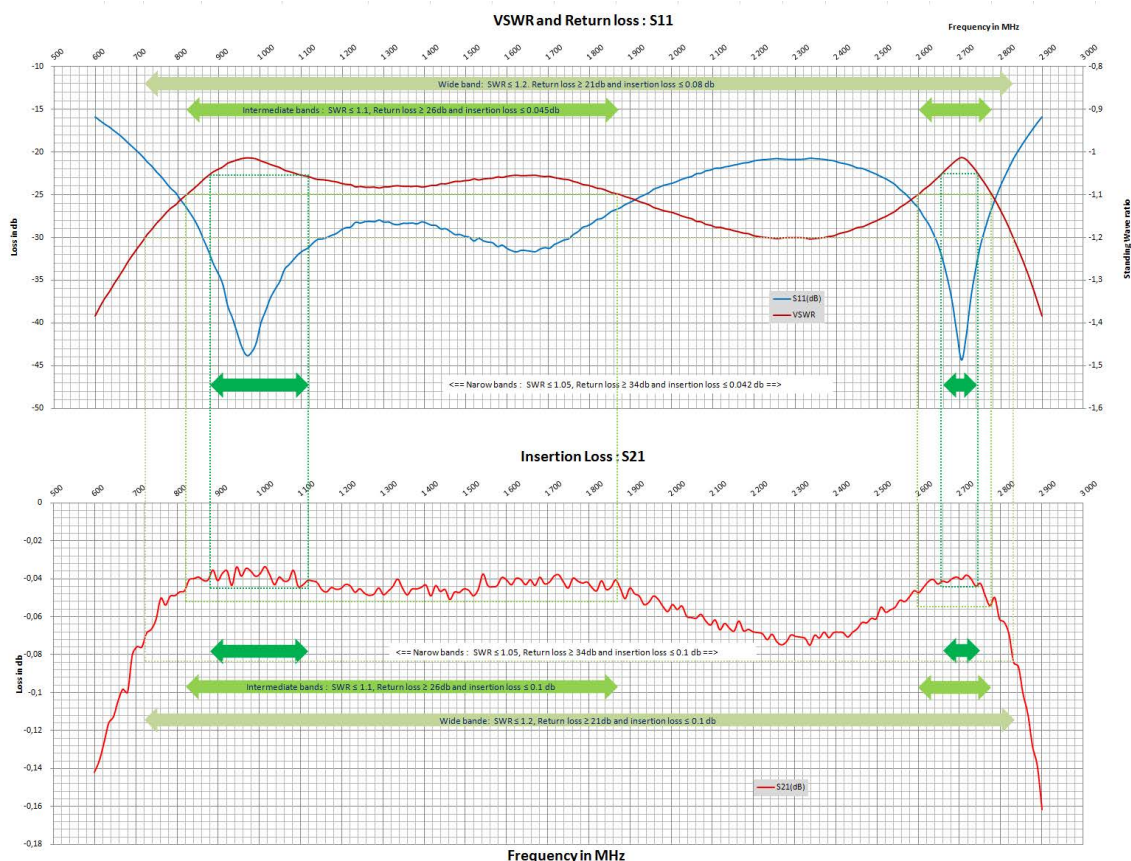

Another presentation format is shown in the following table.

Frequency band		Wide	Intermediate low	Intermediate high	Narrow low	Narrow high
	(MHz)	720-2830	820-1970	2600-2780	880-1120	2655-2745
VSWR	-	< 1.2	< 1.1		< 1.05	
Return loss	(dB)	> 21	> 26		> 34	
Insertion loss	(dB)	< 0.09	< 0.045		< 0.042	

In general wide band characteristics provided are sufficient for good selection of SPDs and for general application. Specific characteristics are available on request for specific frequencies.



P8AX09-N/MF

P8AX SERIES



- Low insertion losses
- Waterproof
- Removable GDT
- DC-pass
- Bi-directional protection

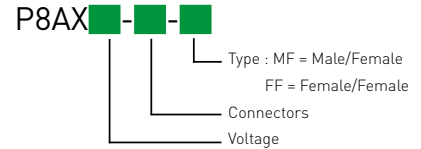

Characteristics

CITEL Model	P8AX09*	P8AX15*	P8AX25*	P8AX50*
Description	RF coaxial protector - 3.5 GHz			
Technology	Gas discharge tube	Gas discharge tube	Gas discharge tube	Gas discharge tube
Frequency range	f DC-3.5GHz	DC-3.5GHz	DC-3.5GHz	DC-3.5GHz
Max Power	P 25 W	70 W	190 W	780 W
Impedance	Z 50/75 ohms	50/75 ohms	50/75 ohms	50/75 ohms
Insertion loss	< 0.2dB	< 0.2dB	< 0.2dB	< 0.2dB
Return loss	> 20 dB	> 20 dB	> 20 dB	> 20 dB
VSWR	<1.2:1	<1.2:1	<1.2:1	<1.2:1
Max. Load current	IL 10A	10A	10A	10A
Nominal discharge current - 8/20µs Test x 10 - C2 Category	In 5 kA	5 kA	5 kA	5 kA
Max. discharge current - max. withstand @ 8/20 µs by pole	Imax 20 kA	20 kA	20 kA	20 kA
Impulse current - 2 x 10/350µs Test - D1 Category	Iimp 2.5 kA	2.5 kA	2.5 kA	2.5 kA
Protection level @ 1kV/µs - C3 Category	Up < 650 V	< 700 V	< 800 V	<1200 V
Typical let through energy [50 ohms] input 4kV 1.2/50µs - 2kA 8/20µs	300 µJ	320 µJ	350 µJ	1100 µJ
End of life behavior	Short-circuit (fault mode 2 - Transmission interruption)			
Mechanical characteristics				
Dimensions	see diagram			
Connection to Network	N . TNC. SMA. F. BNC. 7/16, 4,3-10			
Disconnection indicator	transmission interrupt			
Mounting	Feedthrough			
Operating temperature	-40/+85°C			
Protection rating	IP66			
Housing material	Brass/Surface plating: Cu Zn Sn			
Contacts	Bronze/Surface plating: Au or Ag			
Insulation material	PTFE			
RohS compliance	yes			
Spare unit	BBHF-90V	BBHF-150V	BBHF-250V	BBHF-500V
Standards				
Compliance	IEC 61643-21 / EN 61643-21 / UL497C / UL497E			
* Part number				
BNC connector Female/Female	P8AX09-B/FF 60111	P8AX15-B/FF 60112	P8AX25-B/FF 60114	P8AX50-B/FF 60117
BNC connector Male/Female	P8AX09-B/MF 60101	P8AX15-B/MF 60102	P8AX25-B/MF 60104	P8AX50-B/MF 60107
N connector Female/Female	P8AX09-N/FF 60011	P8AX15-N/FF 60012	P8AX25-N/FF 60014	P8AX50-N/FF 60017
N connector Male/Female	P8AX09-N/MF 60001	P8AX15-N/MF 60002	P8AX25-N/MF 60004	P8AX50-N/MF 60007
F connector Female/Female	P8AX09-F/FF 60211	P8AX15-F/FF 60212	P8AX25-F/FF 60214	P8AX50-F/FF -
F connector Male/Female	P8AX09-F/MF 60201	P8AX15-F/MF -	P8AX25-F/MF 60204	P8AX50-F/MF -
SMA connector Female/Female	P8AX09-SMA/FF 60511	P8AX15-SMA/FF 60512	P8AX25-SMA/FF 60514	P8AX50-SMA/FF -
SMA connector Male/Female	P8AX09-SMA/MF 60501	P8AX15-SMA/MF 60502	P8AX25-SMA/MF 60504	P8AX50-SMA/MF -
7/16 connector Male/Female	P8AX09-716/MF 60401	P8AX15-716/MF -	P8AX25-716/MF 60404	P8AX50-716/MF 60407
7/16 connector Female/Female	P8AX09-716/FF 60411	P8AX15-716/FF -	P8AX25-716/FF 60414	P8AX50-716/FF 60417
4.3-10 connector Male/Female	P8AX09-4310/MF 60901	P8AX15-4310/MF -	P8AX25-4310/MF 60904	P8AX50-4310/MF 60907
4.3-10 connector Female/Female	P8AX09-4310/FF -	P8AX15-4310/FF -	P8AX25-4310/FF -	P8AX50-4310/FF -

Note : If no ordering code, please contact us for more information

RF COAXIAL PROTECTORS - 3.5 GHZ

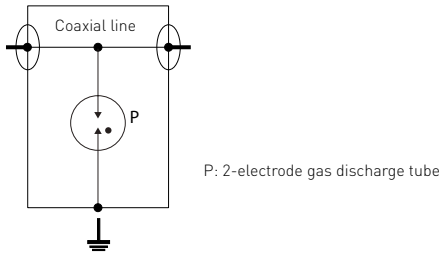

P8AX_-B/FF

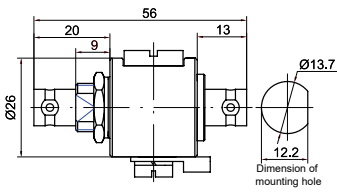

P8AX_-B/MF

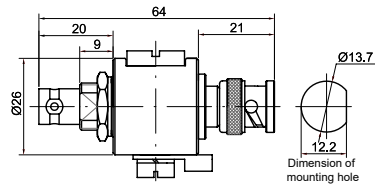

P8AX_-N/FF

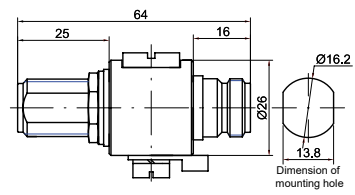

P8AX_-N/MF

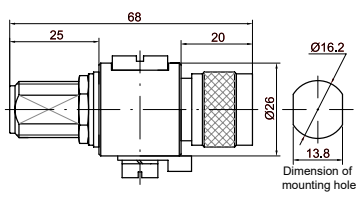

P8AX_-F/FF

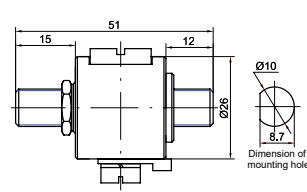

P8AX_-F/MF

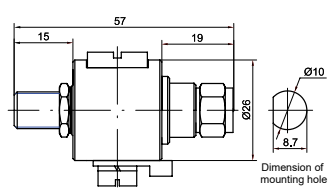

P8AX_-SMA/FF

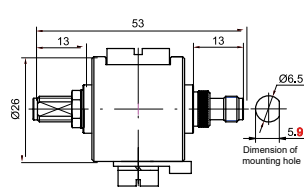

P8AX_-SMA/MF

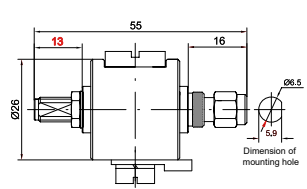

P8AX_-716/FF

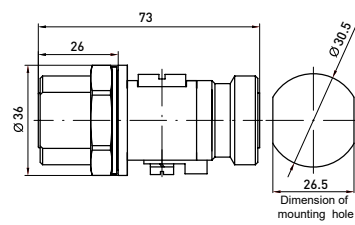

P8AX_-716/MF

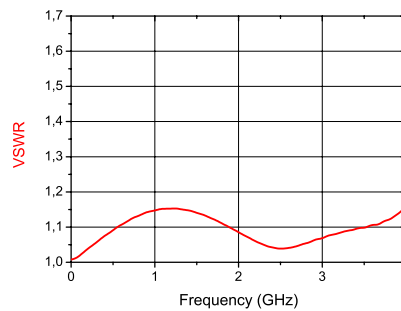
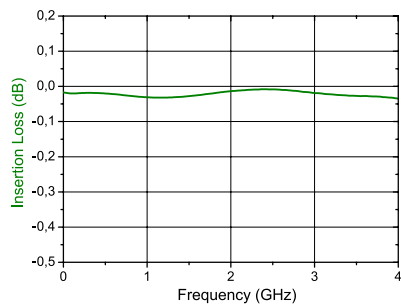
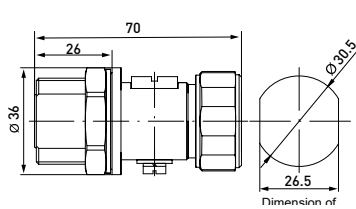



P8AX09-6G-N/MF

P8AX-6G SERIES



- Low insertion losses
- Waterproof
- Removable GDT
- DC-pass
- Bi-directional protection

P8AX -6G- -MF

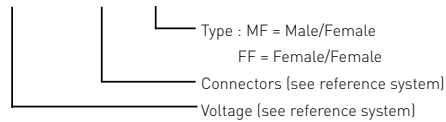

Example: P8AX-6G-N/MF

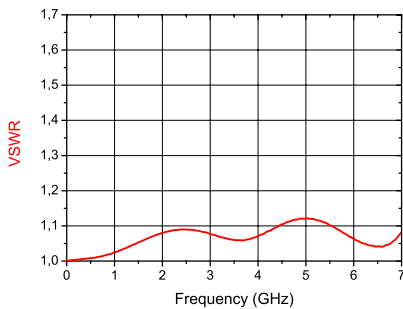
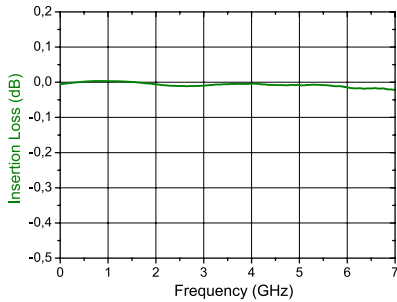
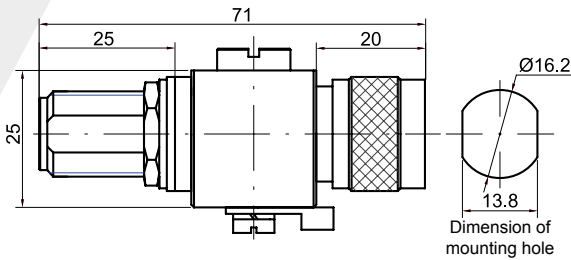

Characteristics

CITEL Model	P8AX09-6G*	P8AX25-6G*
Description	RF coaxial protector - 7 GHz	
Technology	Gas discharge tube	Gas discharge tube
Frequency range	f DC-7 GHz	DC-7 GHz
Max Power	P 25 W	190 W
Impedance	Z 50 ohms	50 ohms
Insertion loss	< 0.2dB	< 0.2dB
Return loss	> 20 dB	> 20 dB
VSWR	<1.25:1	<1.25:1
Max. Load current	IL 10A	10A
Nominal discharge current <i>8/20µs Test x 10 - C2 Category</i>	In 5 kA	5 kA
Max. discharge current <i>max. withstand @ 8/20 µs by pole</i>	I _{max} 20 kA	20 kA
Impulse current <i>2 x 10/350µs Test - D1 Category</i>	I _{imp} 2.5 kA	2.5 kA
Protection level @1 kV/µs - C3 Category	Up < 1100 V	< 1200 V
Typical let through energy (50 ohms) <i>Input 4kV 1.2/50µs - 2kA 8/20µs</i>	2.2 mJ	2.2 mJ
End of life behavior	Short-circuit (fault mode 2 - transmission interruption)	
Mechanical characteristics		
Dimensions	see diagram	
Connection to Network	N, TNC, SMA, 4.3-10	
Disconnection indicator	transmission interrupt	
Mounting	Feedthrough	
Operating temperature	-40/+85°C	
Protection rating	IP66	
Housing material	Brass/Surface plating: Cu Zn Sn	
Contacts	Bronze/Surface plating: Au or -Ag	
Insulation material	PTFE	
RohS compliance	yes	
Spare unit	1 x BA HF -90/20	1 x BA HF -150/20
Standards		
Compliance	IEC 61643-21 / EN 61643-21 / UL497C / UL497E	
* Part number		
TNC connector Female/Female	P8AX09-6G-T/FF 68311	P8AX25-6G-T/FF 68314
TNC connector Male/Female	P8AX09-6G-T/MF 68301	P8AX25-6G-T/MF 68304
N connector Female/Female	P8AX09-6G-N/FF 68011	P8AX25-6G-N/FF 68014
N connector Male/Female	P8AX09-6G-N/MF 68001	P8AX25-6G-N/MF 68004
SMA connector Female/Female	P8AX09-6G-SMA/FF 68511	P8AX25-6G-SMA/FF 68514
SMA connector Male/Female	P8AX09-6G-SMA/MF 68501	P8AX25-6G-SMA/MF 68504
4.3-10 connector Male/Female	P8AX09-6G-4310/MF -	P8AX25-6G-4310/MF -
4.3-10 connector Female/Female	P8AX09-6G-4310/FF -	P8AX25-6G-4310/FF -

* If no ordering code, please contact us for more information

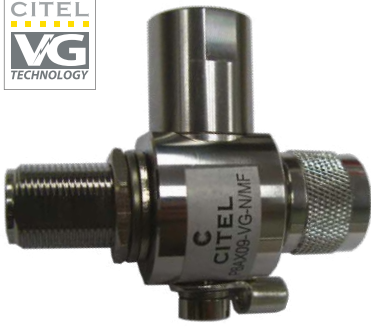

P8AX09-VG-N/MF

P8AX-VG SERIES



- DC to 7 GHz
- I_{max} : 6 kA
- VSWR ≤ 1.25
- Insertion Loss ≤ 0.2 dB
- Feedthrough mounting
- Bi-Directional
- DC pass
- Waterproof

P8AX -6VG- /

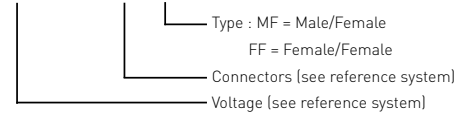

P8AX-VG-N/MF

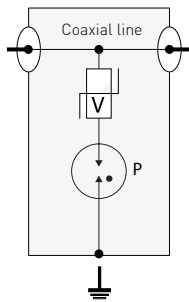
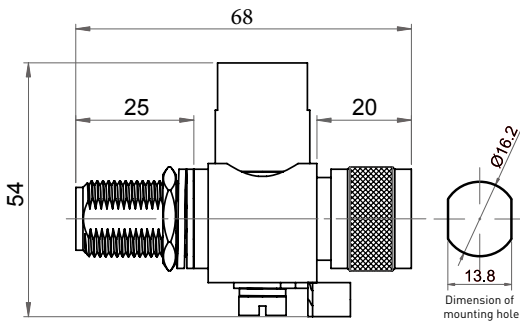

V: Varistor
P: 2-electrode gas tube

Characteristics

CITEL Model	P8AX09-6VG-N/MF	P8AX09-VG-N/MF	P8AX25-VG-F/FF
Description	RF coaxial protector 7 GHz	RF coaxial protector 3.5 GHz	RF coaxial protector 2 GHz
Technology	VG	VG	VG
Frequency range	f DC to 7 GHz	DC to 3.5 GHz	DC to 2 GHz
Max Power	P 70 W	70 W	190 W
Impedance	Z 50 ohms	50 ohms	75 ohms
Insertion loss	< 0.2dB	< 0.2dB	< 0.8dB
Return loss	> 20 dB	> 20 dB	> 13 dB
VSWR	≤ 1.2:1	≤ 1.2:1	≤ 1.5:1
Max. Load current	IL 10A	10A	10A
Nominal discharge current <i>8/20µs Test x 10 - C2 Category</i>	In 3 kA	3 kA	3 kA
Max. discharge current <i>max. withstand @ 8/20 µs by pole</i>	I _{max} 6 kA	6 kA	6 kA
Impulse current <i>2 x 10/350µs Test - D1 Category</i>	I _{imp} 1 kA	1 kA	1 kA
Protection level <i>@ 1kV/µs - C3 Category</i>	U _p < 1200 V	< 800 V	< 900 V
End of life behavior	Short-circuit (fault mode 2 - transmission interruption)		
Mechanical characteristics			
Dimensions	see diagram		
Connection to Network	connector N Male/ Female	connector N Male/ Female	connector F Female/ Female
Disconnection indicator	transmission interrupt		
Mounting	Feedthrough		
Operating temperature	-40/+85°C		
Protection rating	IP66		
Housing material	Brass/Surface plating : Cu Zn Sn		
Contacts	Bronze/Surface plating: Au or -Ag		Bronze/Surface plating: Au
Insulation material	PTFE		
RohS compliance	yes		
Spare unit	-	-	-
Standards			
Compliance	IEC 61643-21 / EN 61643-21 / UL497C / UL497E		
Part number			
	69001	60601	60701

«QUARTER-WAVE» COAXIAL PROTECTORS

PRC SERIES

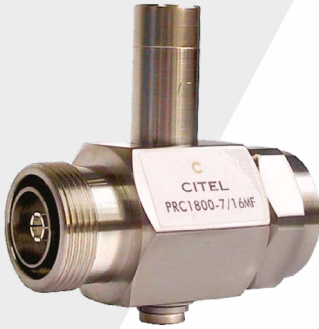

PRC1800-716/MF

- Low insertion losses
- I_{max} > 50 kA
- Available for wide-band application
- No maintenance

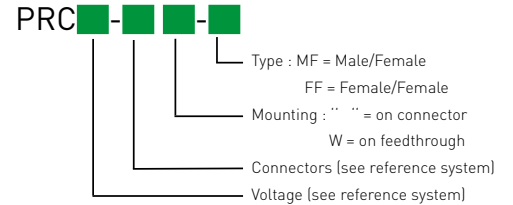

Characteristics

CITEL Model	PRC822S*	PRC900*	PRC1800*	PRC2100*	PRC5800*
Description	"Quarter wave" coaxial protector				
Technology	Quarter Wave	Quarter Wave	Quarter Wave	Quarter Wave	Quarter Wave
Frequency range	f 800-2200MHz	870-960MHz	1700-1950MHz	1800-2400MHz	4500-6000MHz
Max Power	P 1500 W (7/16 = 2500 W)	1500 W (7/16 = 2500 W)	1500 W (7/16 = 2500 W)	1500 W	1500 W
Impedance	Z 50 ohms	50 ohms	50 ohms	50 ohms	50 ohms
Insertion loss	< 0.2 dB	< 0.2 dB	< 0.2 dB	< 0.2 dB	< 0.2 dB
Return loss	> 20 dB	> 20 dB	> 20 dB	> 20 dB	> 20 dB
VSWR	<1.2:1	<1.2:1	<1.2:1	<1.2:1	<1.2:1
PIM 3rd order (2x20W)	<-160 dBc	<-160 dBc	<-160 dBc	<-160 dBc	<-160 dBc
Max. Load current	IL 10A	10A	10A	10A	10A
Nominal discharge current <i>8/20µs Test x 10 - C2 Category</i>	In 25 kA	50 kA	50 kA	25 kA	25 kA
Max. discharge current <i>max. withstand @ 8/20 µs by pole</i>	I _{max} 50 kA	100 kA	100 kA	50 kA	50 kA
Impulse current <i>2 x 10/350µs Test - D1 Category</i>	I _{imp} 25 kA	50 kA	50 kA	25 kA	25 kA
Protection level @ 1kV/µs- C3 Category	Up < 30 V	< 30 V	< 30 V	< 30 V	< 30 V
Failsafe behavior	without	without	without	without	without
Mechanical characteristics					
Dimensions	see diagram				
Connection to Network	N, 4.3-1 or 7/16 connector	N, 4.3-10, TNC or 7/16 connector	N, 4.3-10, TNC or 7/16 connector	N connector	N connector
Mounting	on connector or feedthrough (W version)				connector
Operating temperature	-40/+85°C				
Protection rating	IP66				
Housing material	Brass/Surface plating : Cu Zn Sn				
Contacts	Bronze/Surface plating: Au or -Ag				
Insulation material	PTFE				
Standards					
Compliance	IEC 61643-21 / EN 61643-21 / UL497C / UL497E				
* Part number					
N connector Female/Female	PRC822S-N/FF 61013	PRC900-N/FF 621124	PRC1800-N/FF 621125	PRC2100-N/FF -	PRC5800-N/FF 621151
N connector Male/Female	PRC822S-N/MF 61003	PRC900-N/MF 621111	PRC1800-N/MF 621112	PRC2100-N/MF 621183	PRC5800-N/MF 621112
N connector Female/Female - Feedthrough mounting	-	-	-	PRC2100-NW/ FF 621172	-
N connector Male/Female - Feedthrough mounting	-	-	PRC1800-NW/ MF 61108	PRC2100-NW/ MF	-
T connector Female/Female	-	PRC900-T/FF 621126	PRC1800-T/FF 621127	-	-
T connector Male/Female	-	PRC900-T/MF 621113	PRC1800-T/MF 621115	-	-
7/16 connector Male/Female	PRC822S-716/MF 621139	PRC900-716/MF 621110	PRC1800-716/MF 621108	-	-
7/16 connector Female/Female	PRC822S-716/FF 67413	PRC900-716/FF 621109	PRC1800-716/FF 621107	-	-
4.3-10 connector Male/Female	PRC822S-4310/MF -	PRC900-4310/MF -	PRC1800-4310/MF -	-	-
4.3-10 connector Female/Female	PRC822S-4310/FF -	PRC900-4310/FF -	PRC1800-4310/FF -	-	-

* If no ordering code, please contact us for more information

«QUARTER-WAVE» COAXIAL PROTECTORS

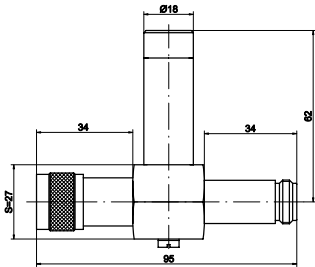

PRC822S-N/MF

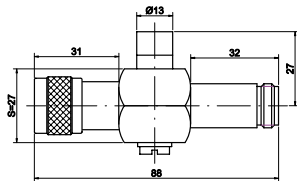

PRC5800-N/MF

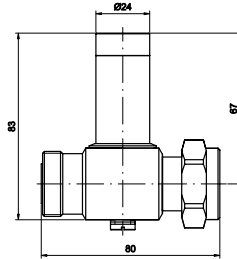

PRC822S-716/MF

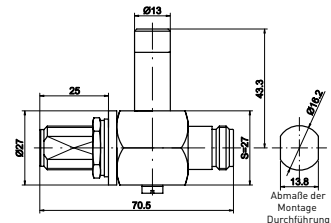

PRC2100-NW/FF

Abmaße der Montage Durchführung

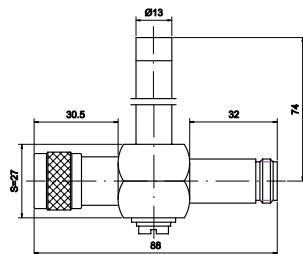

PRC900-N/MF

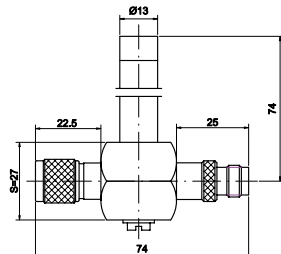

PRC900-T/MF

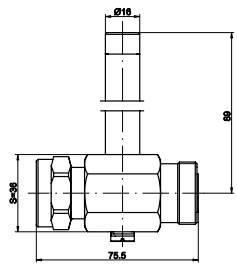

PRC900-716/MF

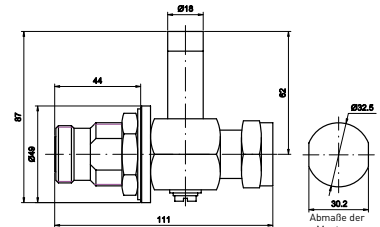

PRC822S-716W/MF

Abmaße der Montage Durchführung

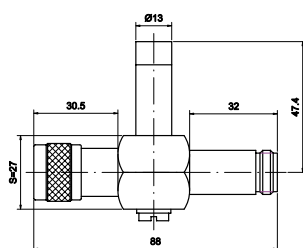

PRC1800-N/MF

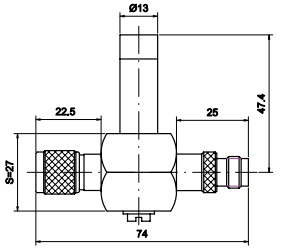

PRC1800-T/MF

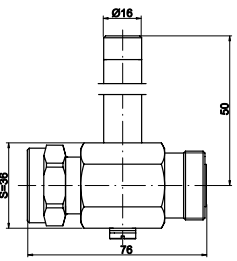

PRC1800-716/MF

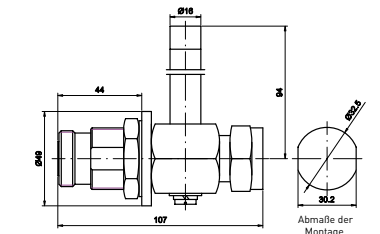

PRC900-716W/MF

Abmaße der Montage Durchführung

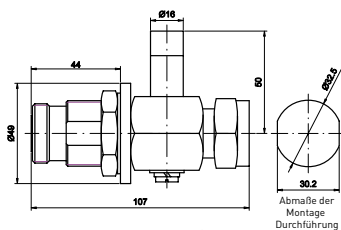

PRC1800-716W/MF

Abmaße der Montage Durchführung

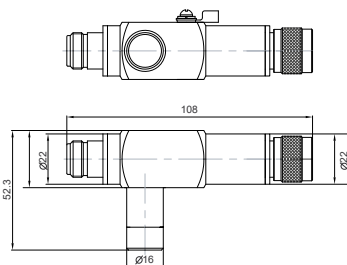

PRC350-N/MF

I

CNP AND CXP SERIES



- RoHS 6 compliance
- Waterproof
- Mounting on plate
- Bi-directional

Characteristics

CITEL Model	CNP90TV-F/*	CNP230TV-F/FF	CXP09*	CXP25*	CXP09*-DCB	CXP25*-DCB
Description	Coaxial SPD for video transmission networks	Coaxial SPD for video transmission networks	Coaxial SPD low frequency	Coaxial SPD low frequency	Coaxial SPD low frequency	Coaxial SPD low frequency
Technology	Gas discharge tube	Gas discharge tube	Gas discharge tube	Gas discharge tube	GDT+Filter	GDT+Filter
Frequency range	f DC-1 GHz	DC-1 GHz	DC-1 GHz	DC-1 GHz	125-1000 MHz	125-1000 MHz
Max Power	P 25 W	190 W	25 W	190 W	25 W	190 W
Impedance	Z 50/75 ohms	50/75 ohms	50/75 ohms	50/75 ohms	50/75 ohms	50/75 ohms
Insertion loss	< 0.6 dB	< 0.6 dB	< 0.5 dB	< 0.5 dB	< 1 dB	< 1 dB
Return loss	> 20 dB	> 20 dB	> 18 dB	> 18 dB	> 20 dB	> 20 dB
VSWR	< 1.35:1	< 1.35:1	< 1.3:1	< 1.3:1	<1.3:1	<1.3:1
Max. Load current	IL 0.5 A	0.5 A	0.5 A	0.5 A	0.5 A	0.5 A
Nominal discharge current <i>8/20µs Test x 10 - C2 Category</i>	In 5 kA	5 kA	5 kA	5 kA	5 kA	5 kA
Max. discharge current <i>-max. withstand @ 8/20 µs by pole</i>	Imax 20 kA	20 kA	20 kA	20 kA	20 kA	20 kA
Impulse current <i>2 x 10/350µs Test - D1 Category</i>	limp 2.5 kA	2.5 kA	2.5 kA	2.5 kA	2.5 kA	2.5 kA
Protection level <i>@ 1kV/µs- C3 Category</i>	Up 600 V	600 V	600 V	600 V	600 V	600 V
End of life behavior	Short-circuit (fault mode 2 - transmission interruption)					
Mechanical characteristics						
Dimensions	see diagram					
Connection to Network	Connector F female/female		N or F connector		N or F connector	
Disconnection indicator	transmission interrupt					
Mounting	on plate					
Operating temperature	-40/+85°C					
Protection rating	IP20					
Housing material	Metal+plastic		Brass			
Standards						
Compliance	IEC 61643-21 / EN 61643-21 / UL497C / UL497E					
*Part number						
N connector Female/Female	-	-	CXP09-N/FF 631655	CXP25-N/FF -	CXP09-N/FF-DCB 631652	CXP25-N/FF-DCB 631752
N connector Male/Female	-	-	CXP09-N/MF -	CXP25-N/MF 631754	CXP09-N/MF-DCB 631653	CXP25-N/MF-DCB 631753
F connector Female/Female	CNP90TV-F/FF 6329012	CNP230TV-F/FF 632302	CXP09-F/FF 631651	CXP25-F/FF 631757	-	-
F connector Male/Female	CNP90TV-F/MF 6329011	-	CXP09-F/MF 631611	CXP25-F/MF -	-	-

* If no ordering code, please contact us for more information

COAXIAL SURGE PROTECTOR LOW FREQUENCY

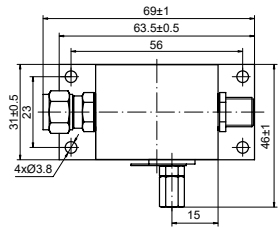

CXP-F/MF

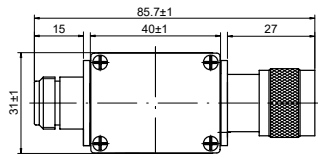

CXP-N/MF

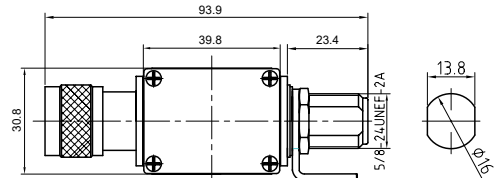

CXP-N/MF/DCB

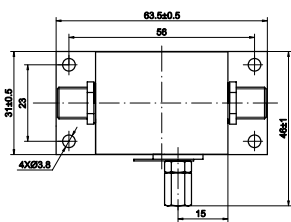

CXP-F/FF

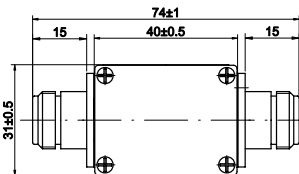

CXP-N/FF

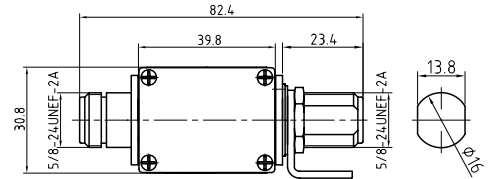

CXP-N/FF/DCB

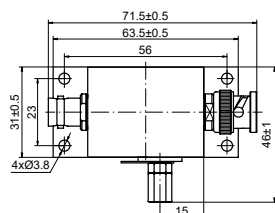

CXP-B/MF

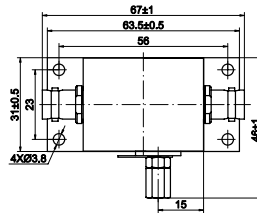

CXP-B/FF

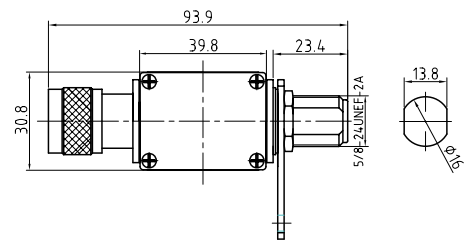

CXP-NW/MF/DCB

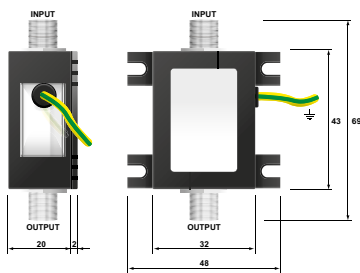

CNP

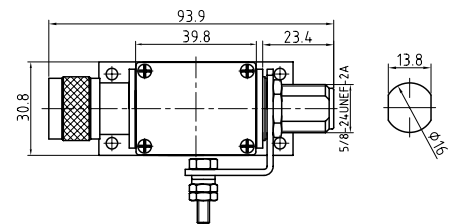

CXP-NW/MF/DCB Bulkhead

CNP
CXP

CXP-DCB

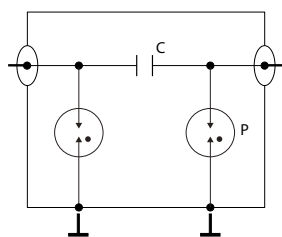
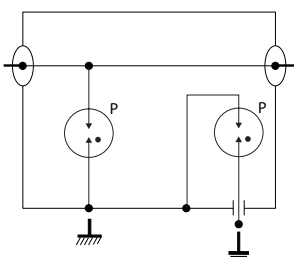

P : Gas discharge tube
C : Capacitance

BRACKET FOR COAXIAL SURGE PROTECTOR

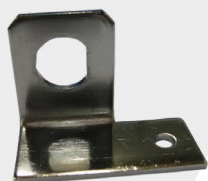

BK-T
bracket for TNC connector



BK-N
bracket for N connector



BK-SMA
bracket for SMA connector

- Screw fixing
- Grounding
- Requires a feedthrough connector

Mounting bracket

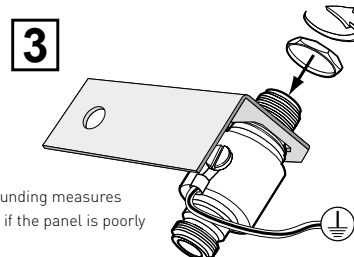
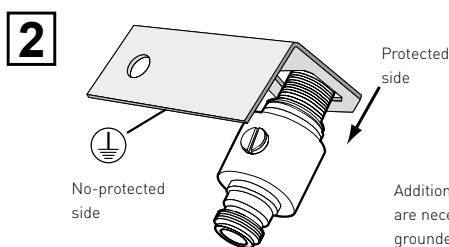
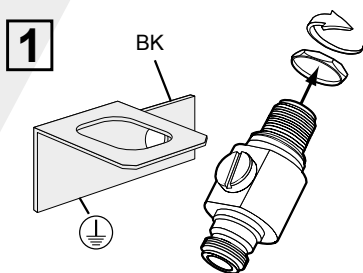

Reference bracket

CITEL	Part number	Connection
BK-D	66001	7/16
BK-F*	66002	F
BK-N*	66003	N
BK-SMA	66006	SMA
BK-T/BK-B	66007	BNC and TNC
BK-U	66011	UHF
BK-43	-	4.3-10

* Mounting brackets are available with various dimensions [Screw hole distance]. Contact us for further information.

GAS DISCHARGE TUBE

- GDT for maintenance of coaxial surge protectors P8AX
- Adapted for use in very high frequency
- Selection according to the RF signal power

Reference	Part number*	for P8AX
BBHF 90/20	927000107	P8AX09-xxx
BBHF 150/20	927000207	P8AX15-xxx
BBHF 250/20	927005907	P8AX25-xxx
BBHF 350/15	927006507	P8AX35-xxx
BBHF 500/20	927002207	P8AX50-xxx
BAHF 90/20	927100107	P8AX09-6G
BAHF 150/20	927100207	P8AX 25-6G

* P/N code is for 10 GDTs packaging



BB HF